

Filterfan

PF 67.000 EMC

Exhaust filter

PFA 60.000 EMC

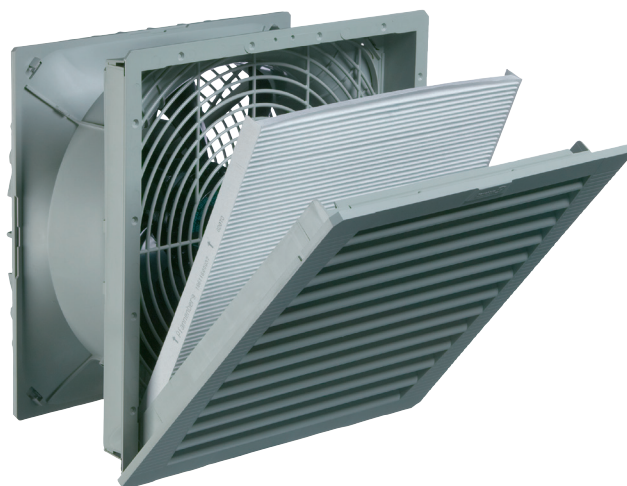

- installation size 6, air flow rate up to 950 m³/h
- three performance classes, cut-out compatible
- secure contact due to improved contact springs on the screen grid
- system of protection IP 54 and IP 55, NEMA type 12
- UL, cUL approval
- UV-resistance (IP 55 version)
- cut-out compatible to installation size 6 of the 3rd and 4th Generation

Data		PF 67.000 EMC			Unit
Article number	IP 54	11867022055	11867102055	11867152055	
	IP 55	11867023055	11867103055	11867153055	
AC 50 Hz / 60 Hz					
Rated voltage ± 10 %		400 / 460 3 ~	230	115	V
Unimpeded airflow	IP 54	845 / 875			m ³ /h
	IP 55	925 / 950			
Airflow rate in combination (PF + PFA 60.000 EMC)	IP 54	560 / 625			
	IP 55	570 / 625			
Power consumption		140 / 170	135 / 200	140 / 195	W
Current consumption		0.35 / 0.43	0.59 / 0.88	1.23 / 1.71	A
Noise level (according to EN ISO 3741)	IP 54	66 / 69			dB (A)
	IP 55				
Weight		3.93			kg
Type of connection		spring-type terminal			
Fuse		6			A
System of protection according to EN 60529 / UL 50	IP 54	NEMA type 12 - standard filter			
	IP 55	NEMA type 12 - fluted filter			
Filtration efficiency	IP 54	91			%
	IP 55				
Filter mat quality class according to EN 779	IP 54	G 4			
	IP 55				
Duty cycle		100			%
Bearing type		ball bearing			
Service life L ₁₀ (+ 40 °C) ¹		40000			h
Temperature range		- 15 ... + 55 / + 5 ... + 131			°C / °F
Design (housing and protection against accidental contact)	IP 54	made of injection-moulded thermoplastic, self-extinguishing, UL 94 VO			
	IP 55	additional: UV-resistant			
EMC screen		stainless steel			
Colour		RAL 7035, different colours available on request			
Accessories		Piece	Article number		Information on page
Exhaust filter PFA 60.000 EMC	IP 54	1	11960002055		160
	IP 55	1	11960003055		160
Thermostat		1	17121000000		176/178

¹ fan failure is defined as being when the current and speed deviate or the operating noises are out of the ordinary
Approvals see page 119

Cooling capacity performance curves

PF 67.000 EMC IP 54

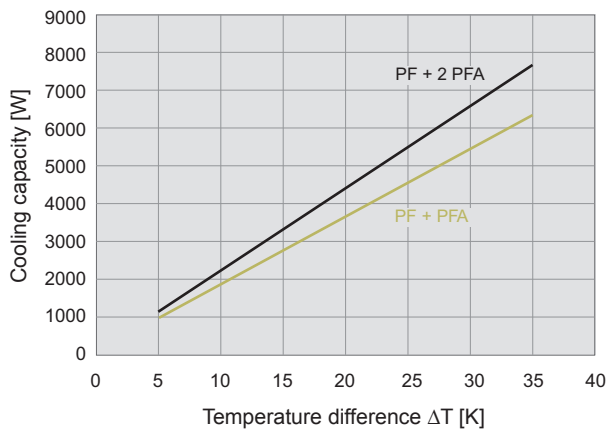

Static pressure performance curves

PF 67.000 EMC IP 54

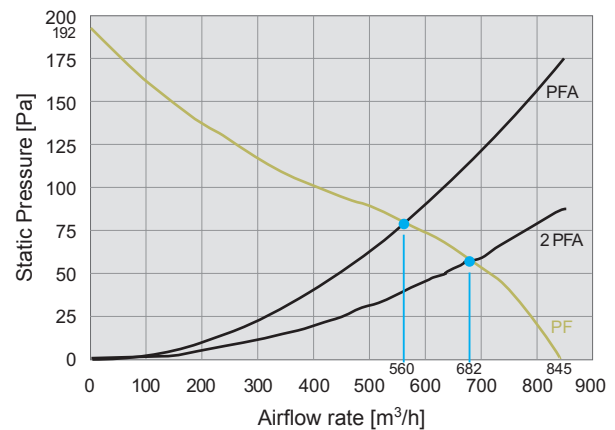

PF 67.000 EMC IP 55

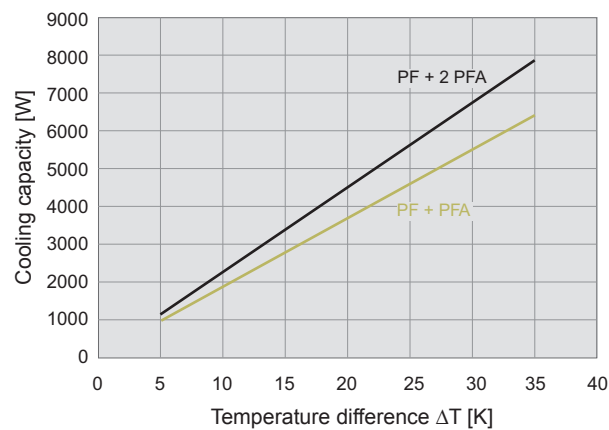

PF 67.000 EMC IP 55

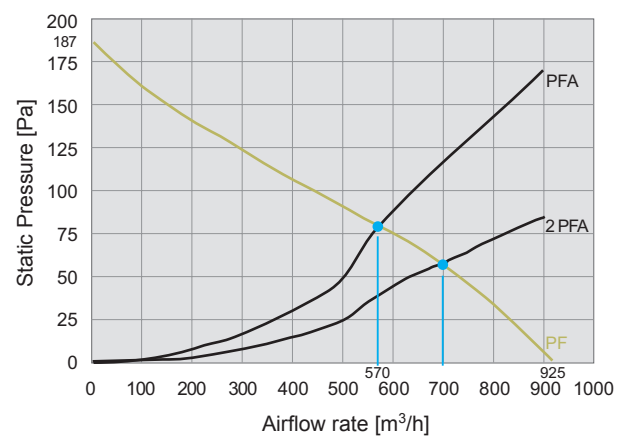

Dimensions

mm	PF 67.000 EMC	PFA 60.000 EMC
X	320	320
Y	320	320
Z1	7	7
Z2	150	39
A	292	292
B	292	292

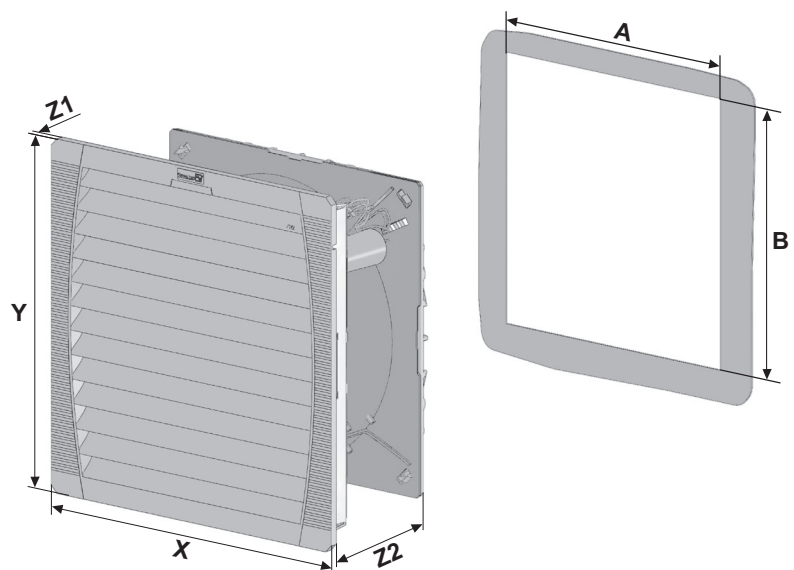

Further information on the EMC Filterfans (EMC series) can be found on page 156.