

# Filterfan

## PF 65.000 EMC

### Exhaust filter

## PFA 60.000 EMC



- installation size 6, air flow rate up to 505 m<sup>3</sup>/h
- three performance classes, cut-out compatible
- secure contact due to improved contact springs on the screen grid
- system of protection IP 54 and IP 55, NEMA type 12
- UL, cUL approval
- UV-resistance (IP 55 version)
- cut-out compatible to installation size 6 of the 3<sup>rd</sup> and 4<sup>th</sup> Generation

Data		PF 65.000 EMC		Unit
Article number	IP 54	11865102055	11865152055	
	IP 55	11865103055	11865153055	
AC 50 Hz / 60 Hz				
Rated voltage ± 10 %		230	115	V
Unimpeded airflow	IP 54	480 / 480		m <sup>3</sup> /h
	IP 55	505 / 505		
Airflow rate in combination (PF + PFA 60.000 EMC)	IP 54	370 / 370		
	IP 55	380 / 380		
Power consumption		65 / 80	75 / 90	W
Current consumption		0.3 / 0.36	0.66 / 0.8	A
Noise level (according to EN ISO 3741)	IP 54	54 / 52		dB (A)
	IP 55			
Weight		3.43		kg
Type of connection		spring-type terminal		
Fuse		6		A
System of protection according to EN 60529 / UL 50	IP 54	NEMA type 12 - standard filter		
	IP 55	NEMA type 12 - fluted filter		
Filtration efficiency	IP 54	91		%
	IP 55			
Filter mat quality class according to EN 779	IP 54	G 4		
	IP 55			
Duty cycle		100		%
Bearing type		ball bearing		
Service life L <sub>10</sub> (+ 40 °C) <sup>1</sup>		40000		h
Temperature range		- 15 ... + 55 / + 5 ... + 131		°C / °F
Design (housing and protection against accidental contact)	IP 54	made of injection-moulded thermoplastic, self-extinguishing, UL 94 VO		
	IP 55	additional: UV-resistant		
EMC screen		stainless steel		
Colour		RAL 7035, different colours available on request		
Accessories		Piece	Article number	Information on page
Exhaust filter PFA 60.000 EMC	IP 54	1	11960002055	160
	IP 55	1	11960003055	160
Thermostat		1	17121000000	176/178

<sup>1</sup> fan failure is defined as being when the current and speed deviate or the operating noises are out of the ordinary  
Approvals see page 119

**Cooling capacity performance curves**

**PF 65.000 EMC IP 54**

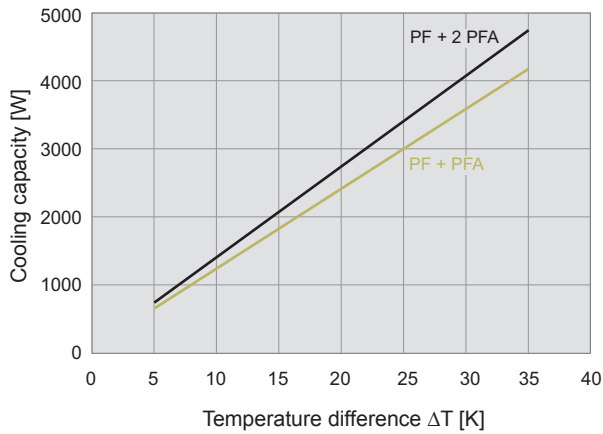

**Static pressure performance curves**

**PF 65.000 EMC IP 54**

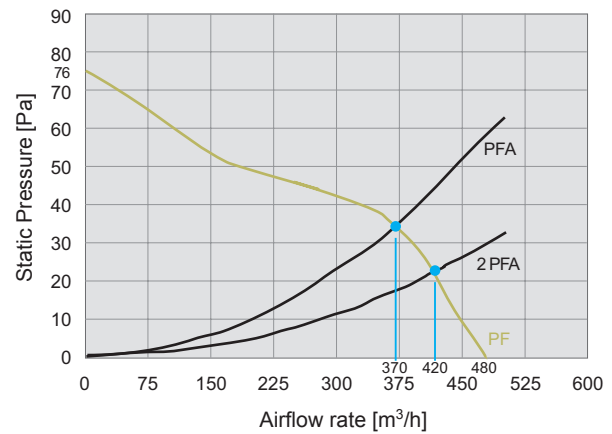

**PF 65.000 EMC IP 55**

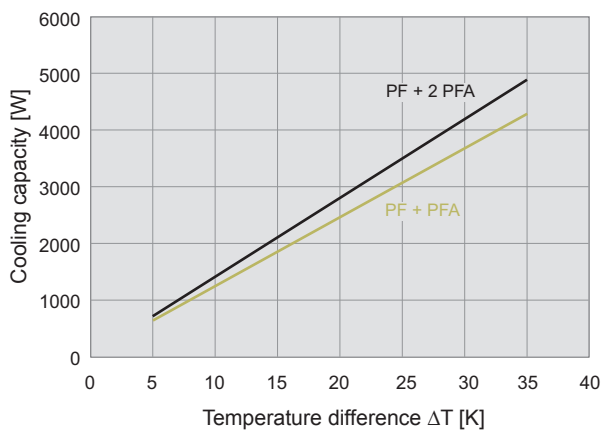

**PF 65.000 EMC IP 55**

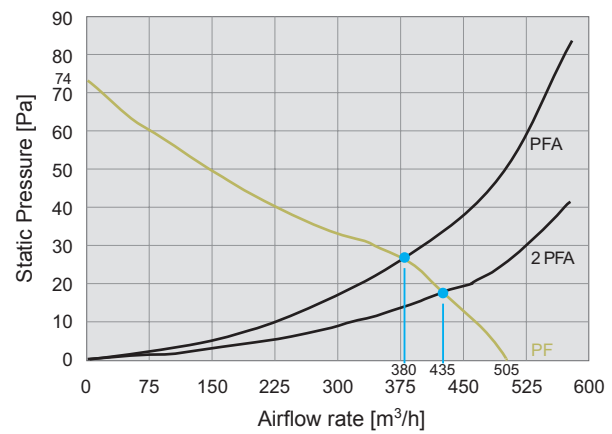

**Dimensions**

mm	PF 65.000 EMC	PFA 60.000 EMC
X	320	320
Y	320	320
Z1	7	7
Z2	150	39
A	292	292
B	292	292

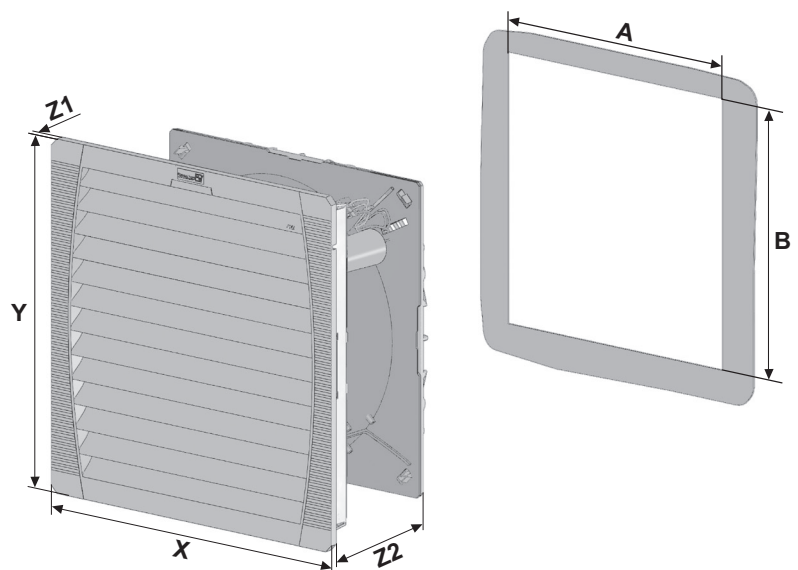

Further information on the EMC Filterfans (EMC series) can be found on page 156.