

Filterfan

PF 43.000 EMC

Exhaust filter

PFA 40.000 EMC



- installation size 4, air flow rate up to 292 m³/h
- two performance classes, cut-out compatible
- secure contact due to improved contact springs on the screen grid
- system of protection IP 54 and IP 55, NEMA type 12
- UL, cUL approval
- UV-resistance (IP 55 version)
- cut-out compatible to installation size 4 of the 3rd and 4th Generation

Data		PF 43.000 EMC					Unit
Article number	IP 54	11843101055	11843151055	11843851055	11843801055	11843701055	
	IP 55	11843103055	11843153055	11843853055	11843803055	11843703055	
		AC 50 Hz / 60 Hz			DC		
Rated voltage ± 10 %		230	115	12	24	48	V
Unimpeded airflow	IP 54	256 / 292					m ³ /h
	IP 55	233 / 265					
Airflow rate in combination (PF + PFA 40.000 EMC)	IP 54	231 / 265					
	IP 55	180 / 207					
Power consumption		45 / 39	40 / 40	12	12	12	W
Current consumption		0.32 / 0.26	0.5 / 0.5	1	0.5	0.25	A
Noise level (according to EN ISO 3741)	IP 54	42 / 46			42		dB (A)
	IP 55						
Weight		1.83			1.77		kg
Type of connection	spring-type terminal						
Fuse	6						A
System of protection according to EN 60529 / UL 50	IP 54	NEMA type 12 - standard filter					
	IP 55	NEMA type 12 - fluted filter					
Filtration efficiency	IP 54	88					%
	IP 55	91					
Filter mat quality class according to EN 779	IP 54	G 3					
	IP 55	G 4					
Duty cycle	100						%
Bearing type	ball bearing						
Service life L ₁₀ (+ 40 °C) ¹	40000			80000			h
Temperature range	- 15 ... + 55 / + 5 ... + 131						°C / °F
Design (housing and protection against accidental contact)	IP 54	made of injection-moulded thermoplastic, self-extinguishing, UL 94 VO					
	IP 55	additional: UV-resistant					
EMC screen	stainless steel						
Colour	RAL 7035, different colours available on request						
Accessories		Piece	Article number			Information on page	
Exhaust filter PFA 40.000 EMC	IP 54	1	11940001055			160	
	IP 55	1	11940003055			160	
Thermostat		1	17121000000			176/178	

¹ fan failure is defined as being when the current and speed deviate or the operating noises are out of the ordinary
Approvals see page 119

Cooling capacity performance curves

PF 43.000 EMC IP 54

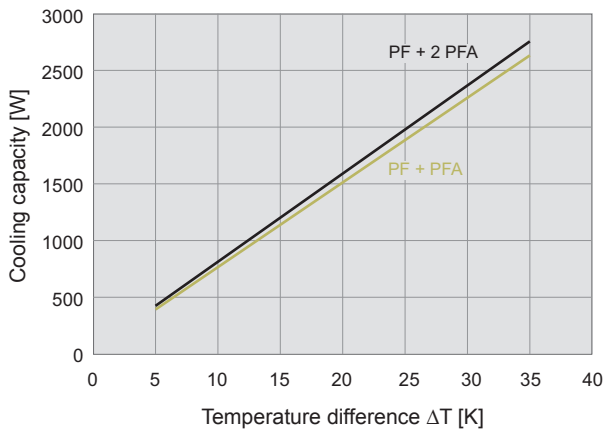

Static pressure performance curves

PF 43.000 EMC IP 54

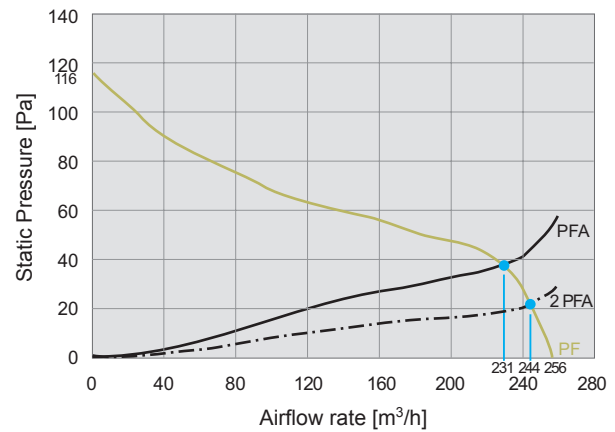

PF 43.000 EMC IP 55

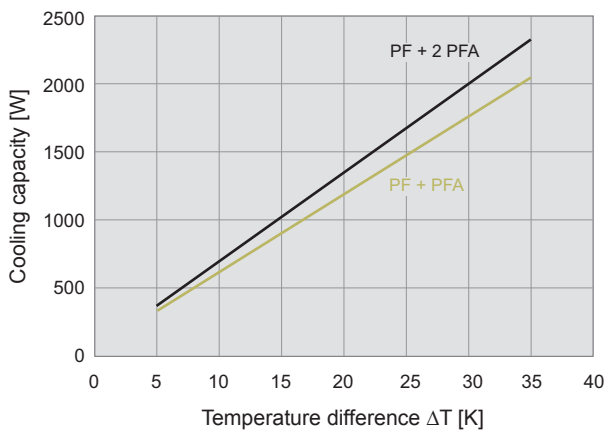

PF 43.000 EMC IP 55

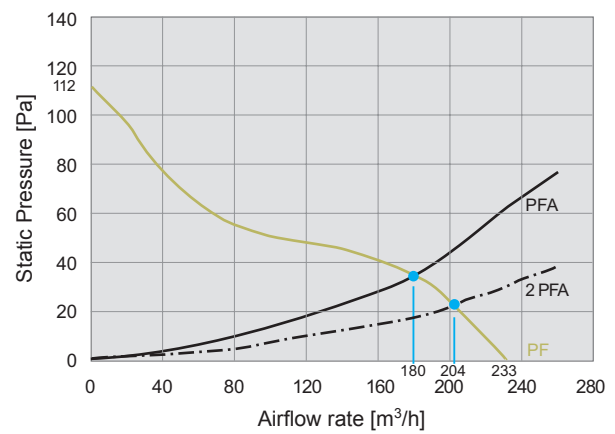

Dimensions

mm	43.000 EMC		PFA 40.000 EMC
	AC	DC	
X	252	252	252
Y	252	252	252
Z1	6	6	6
Z2	113	97	38
A	224	224	224
B	224	224	224

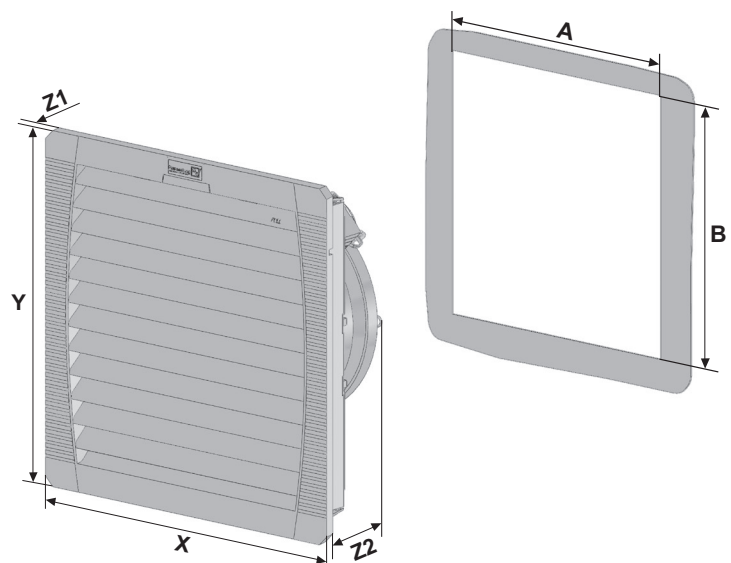

Further information on the EMC Filterfans (EMC series) can be found on page 156.