

Filterfan

PF 22.000 EMC

Exhaust filter

PFA 20.000 EMC



- installation size 2, air flow rate up to 70 m³/h
- secure contact due to improved contact springs on the screen grid
- system of protection IP 54 and IP 55, NEMA type 12
- UL, cUL approval
- UV-resistance (IP 55 version)
- cut-out compatible to installation size 2 of the 3rd and 4th Generation

Data		PF 22.000 EMC					Unit
Article number	IP 54	11822101055	11822151055	11822851055	11822801055	11822701055	
	IP 55	11822103055	11822153055	11822853055	11822803055	11822703055	
		AC 50 Hz / 60 Hz			DC		
Rated voltage ± 10 %		230	115	12	24	48	V
Unimpeded airflow	IP 54	61 / 70					m ³ /h
	IP 55	56 / 64					
Airflow rate in combination (PF + PFA 20.000 EMC)	IP 54	44 / 52					
	IP 55	40 / 46					
Power consumption		19 / 18	20 / 20	5	5	5	W
Current consumption		0.12 / 0.18	0.24 / 0.23	0.42	0.21	0.1	A
Noise level (according to EN ISO 3741)	IP 54	44 / 44			44		dB (A)
	IP 55						
Weight		0.78			0.49		kg
Type of connection		terminal strip			cable, 2-core, length 310 mm		
Fuse		6					A
System of protection according to EN 60529 / UL 50	IP 54	NEMA type 12 - standard filter					
	IP 55	NEMA type 12 - fluted filter					
Filtration efficiency	IP 54	88					%
	IP 55	91					
Filter mat quality class according to EN 779	IP 54	G 3					
	IP 55	G 4					
Duty cycle		100					%
Bearing type		sleeve bearing			ball bearing		
Service life L ₁₀ (+ 40 °C) ¹		37500	40000	62500			h
Temperature range		- 15 ... + 55 / + 5 ... + 131					°C / °F
Design (housing and protection against accidental contact)	IP 54	made of injection-moulded thermoplastic, self-extinguishing, UL 94 VO					
	IP 55	additional: UV-resistant					
EMC screen		stainless steel					
Colour		RAL 7035, different colours available on request					
Accessories		Piece	Article number			Information on page	
Exhaust filter PFA 20.000 EMC	IP 54	1	11920001055			160	
	IP 55	1	11920003055			160	
Thermostat		1	17121000000			176/178	

¹ fan failure is defined as being when the current and speed deviate or the operating noises are out of the ordinary
Approvals see page 119

Cooling capacity performance curves

PF 22.000 EMC IP 54

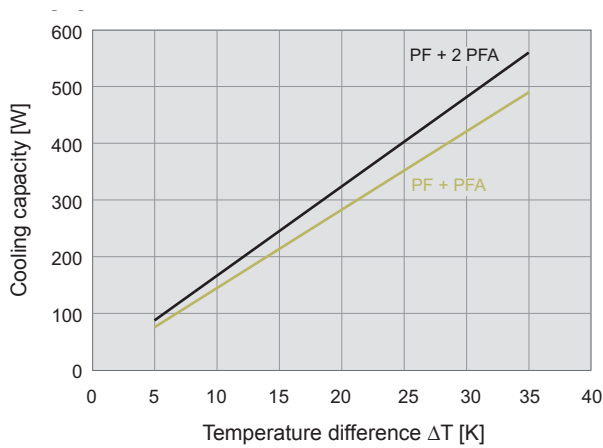

Static pressure performance curves

PF 22.000 EMC IP 54

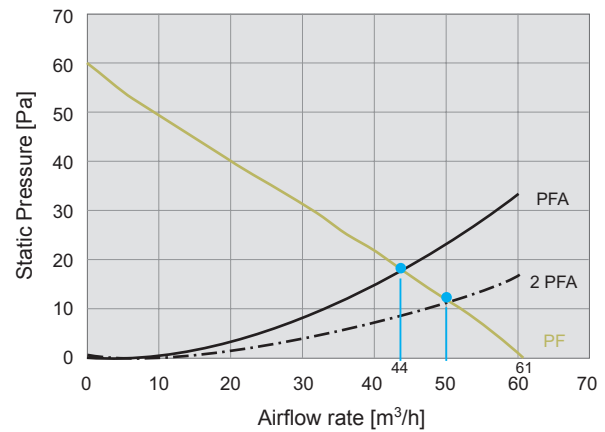

PF 22.000 EMC IP 55

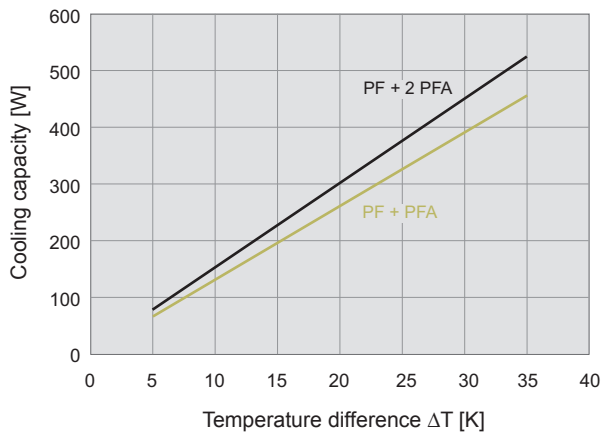

PF 22.000 EMC IP 55

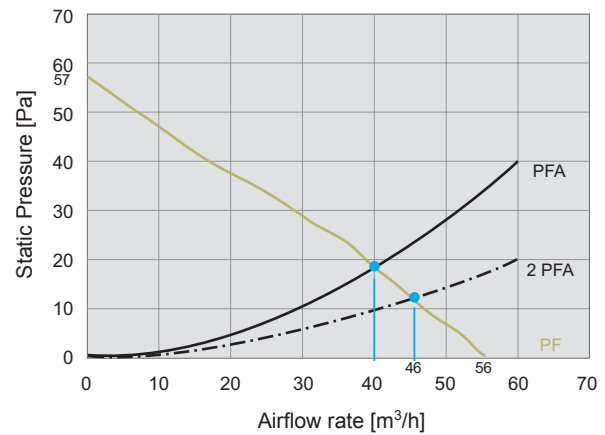

Dimensions

mm	PF 22.000 EMC		PFA 20.000 EMC
	AC	DC	
X	145	145	145
Y	145	145	145
Z1	5	5	5
Z2	70	64	26
A	126	126	126
B	126	126	126

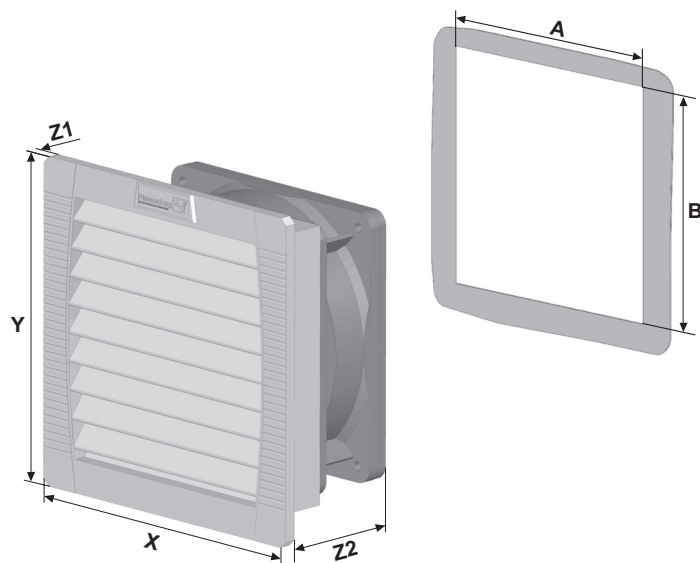

Further information on the EMC Filterfans (EMC series) can be found on page 156.